

ART. C965S

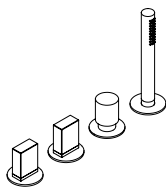

ART. C967S

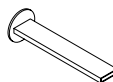

ART. C945

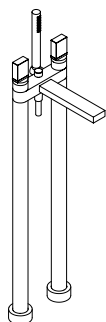

ART. C980SB

Utensili necessari / Tools needed / Outils nécessaires / Werkzeuge benötigt / Instrumentos necesarios

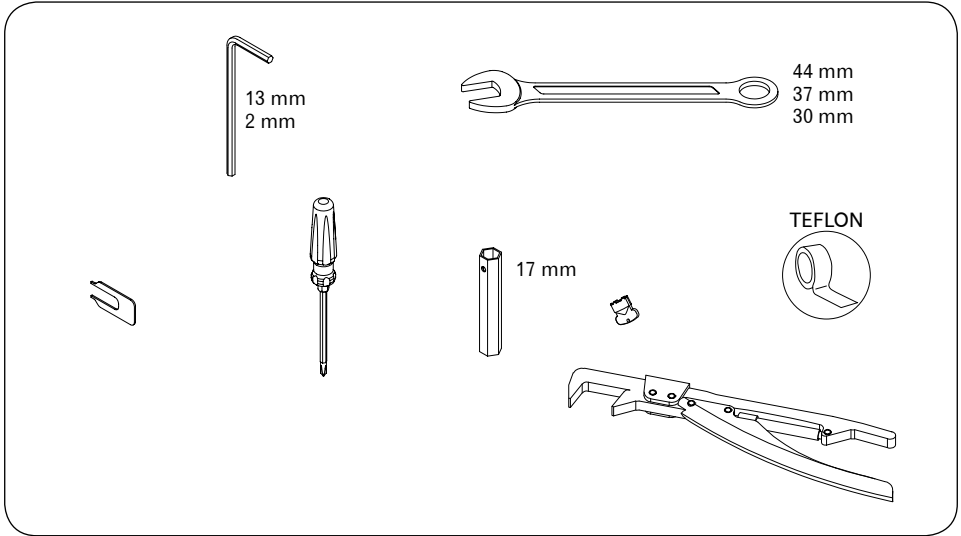

Indice / Index / Index / Übersicht / Índice

Montaggio flessibili / Flexible mounting	4
C965 Bordo vasca con bocca / Bath side group with spout / Bain-douche sur gorge avec bec / Wannenrandbatterie mit Auslauf / Bateria horizontal bañera con cano	6
C967 Bordo vasca / Bath side group / Bain-douche sur gorge / Wannenrandbatterie / Bateria horizontal bañera	6
Regolazioni / Adjustments / Ajustements / Anpassungen / Ajustes	11
C945 Bocca a muro / Wall-mount spout / Bec murale / Wandeinlauf / Caño a pared	16
Sostituzione vitone / Bolt Replacement / Ajustements / Anpassungen / Ajustes	18
Sostituzione aeratore / Substitute aerator / Remplacement de l'aérateur / Den Lüfter auswechseln / Sustituir el aireador	19
C980SB Parte esterna / External pieces / Parties externes / Up-Teil / Parte externa	20
Regolazioni / Adjustments / Ajustements / Anpassungen / Ajustes	22
Sostituzione vitone / Bolt replacement / Remplacement de la tête / Oberteilersetzung / Sustitucion rosca de extrusion	23
Sostituzione deviatore / Bolt replacement / Remplacement de la tête / Oberteilersetzung / Sustitucion rosca de extrusion	24
Sostituzione rompigitto / Substitute aerator / Remplacement de l'aérateur / Den Lüfter auswechseln / Sustitucion el aireador	25
Dati tecnici / Technical data / Caractéristiques techniques / Technische Daten / Datos Técnicos	26

Montaggio flessibili / Flexible mounting



Prima dell'installazione controllare la presenza e l'integrità delle graffature dei flessibili da ambo i lati.

/ Before installation, check presence and integrity of the clamping of the side tubes.



Avvitare i raccordi con tenuta O.R. a mano. Coppia massima di serraggio 3 Nm.

/ Hand-tighten O-ring seal connectors.

Max torque 3 Nm.

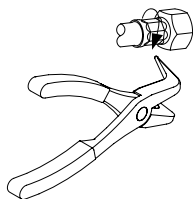

Non serrare con utensili non adatti o in punti non corretti.

/ Do not tighten by inappropriate tools or in inappropriate ways.

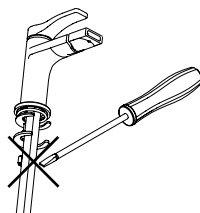

Dopo il montaggio evitare sollecitazioni laterali anche minime, con qualsiasi utensile.

(Es.: durante il fissaggio del tirante o astina).

/ Do not expose the hose to lateral stress nor overtight by any tool. (Ex.: during the installation of the faucet stud or the drain pop-up lever).

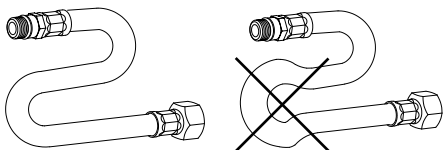

Rispettare il raggio minimo di curvatura.

/ Maintain minimum bend radius.

DN6 = 25 mm DN8 = 30 mm
DN10 = 35 mm DN13 = 45 mm

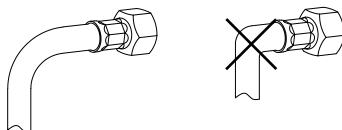

Prima dell'inizio della curvatura lasciare un tratto rettilineo di almeno 1,5 - 2 volte il diametro esterno.

/ Before bending the hose please consider a straight part of at least 1,5-2 times the external diameter.

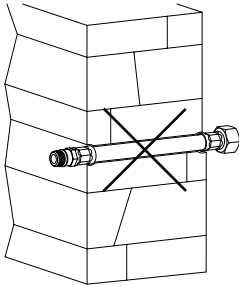

Non incassare il condotto nel muro.
/ Do not set the hose in the wall.

7.



Non installare il flessibile in torsione o in tensione.
/ Tighten the hose without any twist or tension.

8.

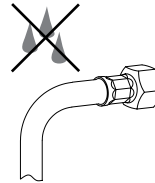

Il contatto prolungato con sostanze, pur blandamente aggressive, può determinare il danneggiamento della treccia ed il conseguente scoppio del flessibile.
/ Prolonged contact with any substance, even scarcely aggressive, can cause external braid damage and subsequent flexible burst.

10.



Avvitare i raccordi con tenuta a guarnizione (dadi) a mano più 1/4 di giro con chiave appropriata.
/ Hand-tighten connectors with gasket seal (nuts) then apply 1/4 turn using an appropriate wrench.

9.

Non collegare la messa a terra dell'impianto elettrico al flessibile o ad altra condotta idraulica. Chiudere l'impianto idraulico in caso di prolungata assenza. Sostituire il flessibile in caso di piccole perdite.

/ Do not connect the electric grounding to the flexible hose nor to any other water piping.
Turn off the plumbing in case of long absence. Replace the hose in case of leakage and anyway.

11.

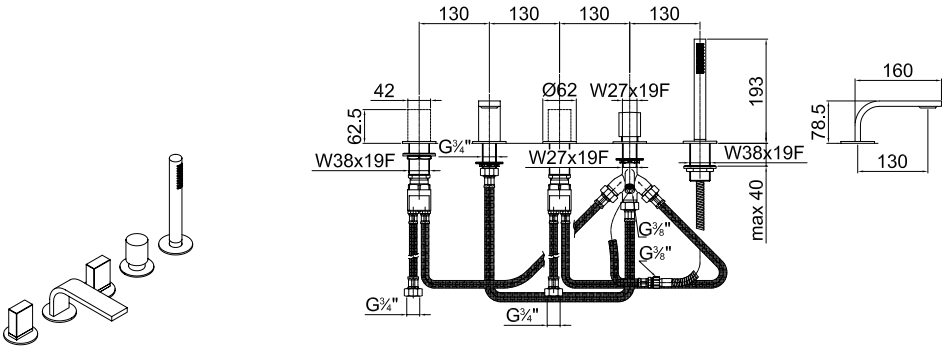

ART. C965

Bordo vasca con bocca / Bath side group with spout / Bain-douche sur gorge avec bec / Wannenrandbatterie mit Auslauf / Bateria horizontal bañera con cano

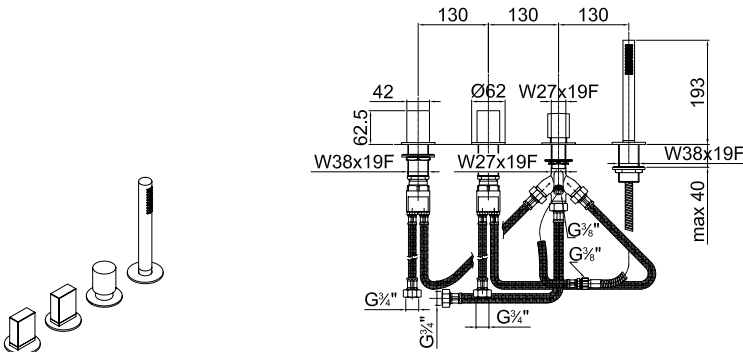

ART. C967

Bordo vasca / Bath side group / Bain-douche sur gorge / Wannenrandbatterie / Bateria horizontal bañera

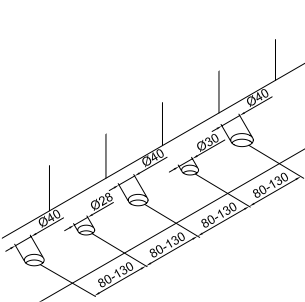

ART. C965

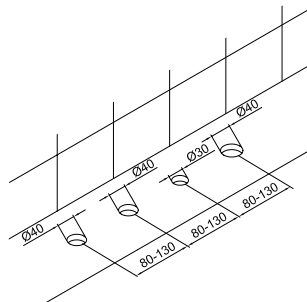

ART. C967

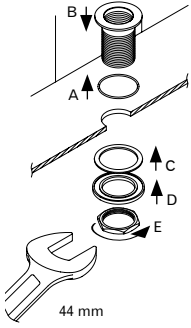

1.

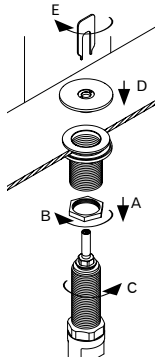

2.

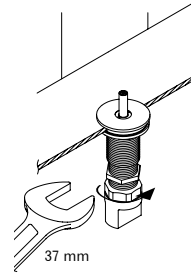

3.

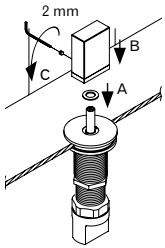

4.

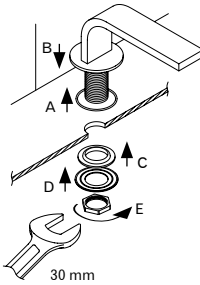

5.

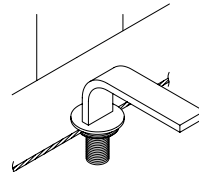

6.

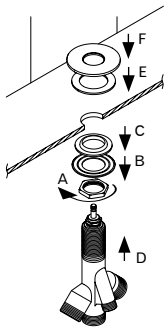

7.

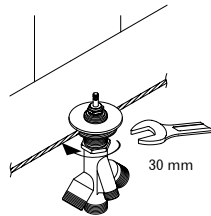

8.

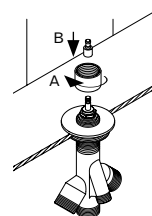

9.

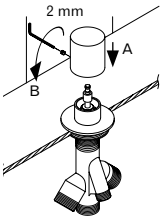

10.

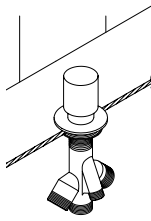

11.

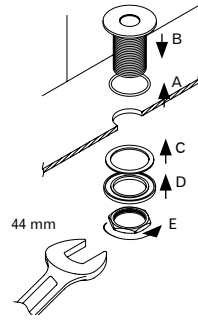

12.

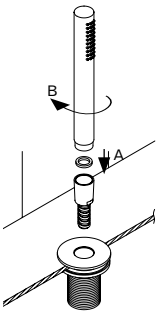

13.

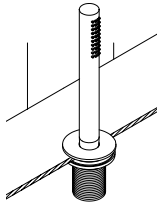

14.

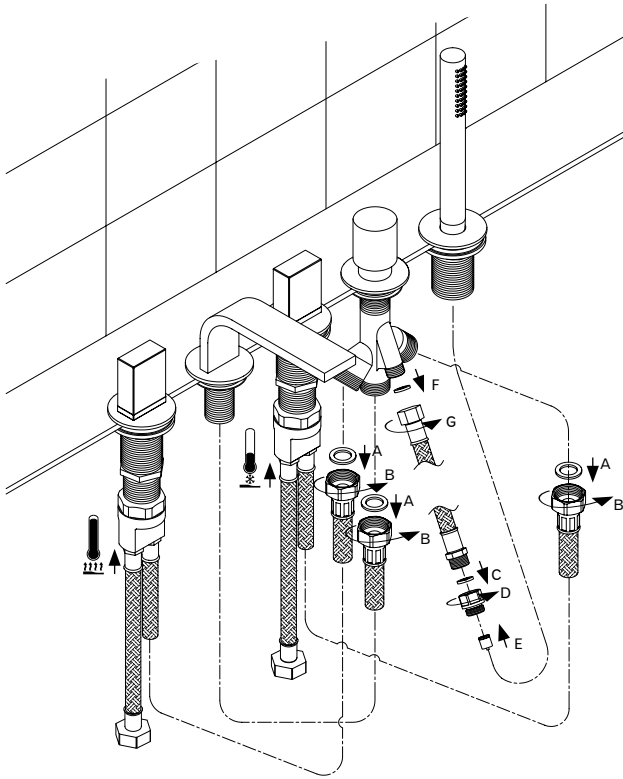

15. ART. C965



- Collegare i flessibili di entrata in corrispondenza della freccia posta sul corpo
- Connect the inlet hoses at the arrow on the valve body
- Raccordez les tuyaux d'entrée à la flèche sur le corps du robinet
- Verbinden Sie die Schläuche der Eintrag bei dem Pfeil auf dem Ventilkörper
- Conecte las mangueras de entrada a la flecha en el cuerpo de la válvula

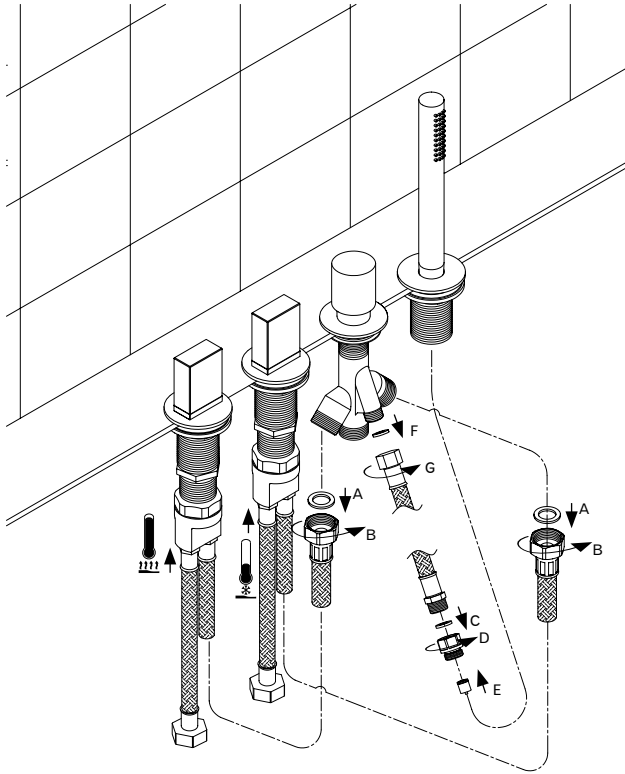

15. ART. C967



- Collegare i flessibili di entrata in corrispondenza della freccia posta sul corpo
- Connect the inlet hoses at the arrow on the valve body
- Raccordez les tuyaux d'entrée à la flèche sur le corps du robinet
- Verbinden Sie die Schläuche der Eintrag bei dem Pfeil auf dem Ventilkörper
- Conecte las mangueras de entrada a la flecha en el cuerpo de la válvula

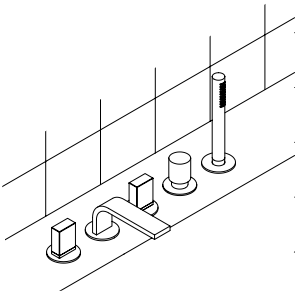

16. ART. C965

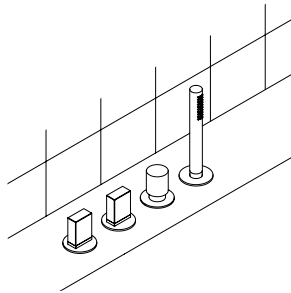

16. ART. C967

Regolazioni / Adjustments / Ajustements / Anpassungen / Ajustes

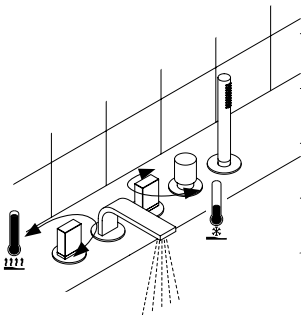

ART. C965

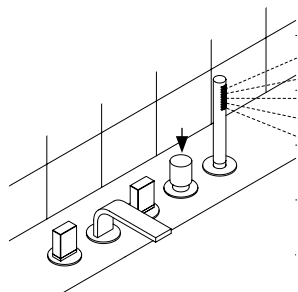

ART. C965

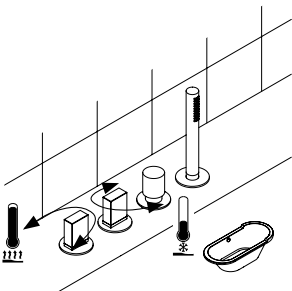

ART. C967

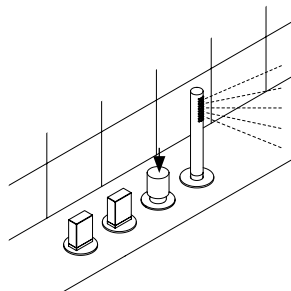

ART. C967

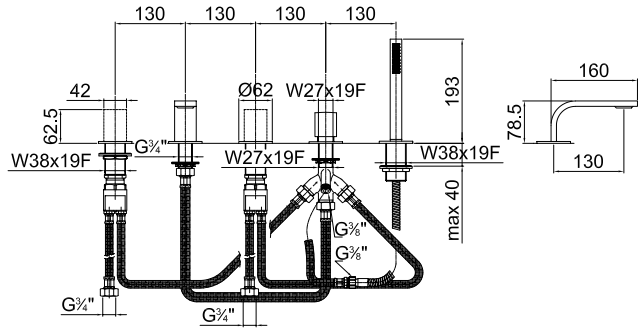
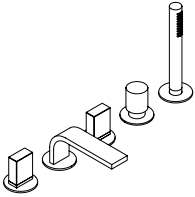

ART. C965

Bordo vasca con bocca / Bath side group with spout / Bain-douche sur gorge avec bec / Wannenrandbatterie mit Auslauf / Bateria horizontal bañera con cano

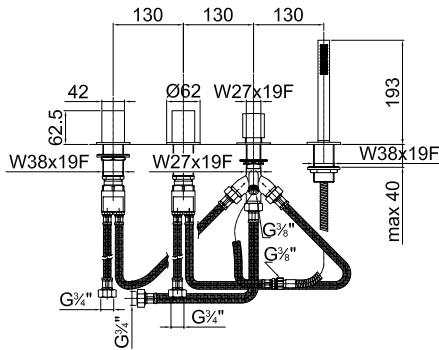
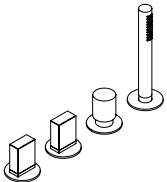

ART. C967

Bordo vasca / Bath side group / Bain-douche sur gorge / Wannenrandbatterie / Bateria horizontal bañera



- Effettuare la procedura seguente per montaggio su piastre 9009670 e 9009325
- Carry out the following procedure for mounting on plates 9009670 and 9009325
- Suivre la procédure suivante pour monter sur des plaques 9009670 et 9009325
- Die nachstehende Prozedur für die Montierung auf die Platten 9009670 und 9009325 befolgen
- Suivre la procédure suivante pour monter sur des plaques 9009670 et 9009325

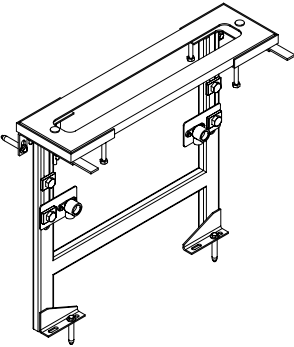

ART. 9009670

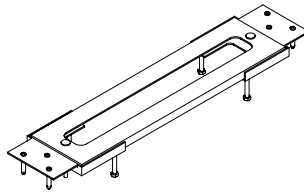

ART. 9009325

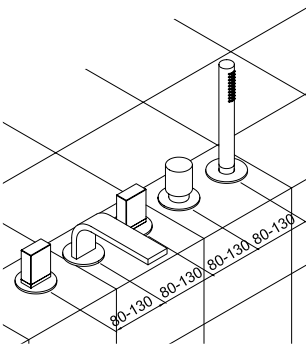

1. ART. C965

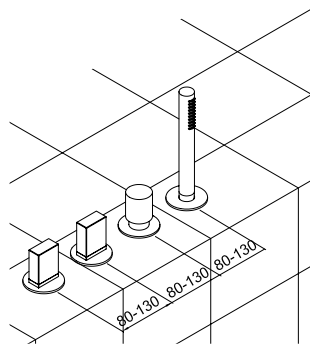

1. ART. C967

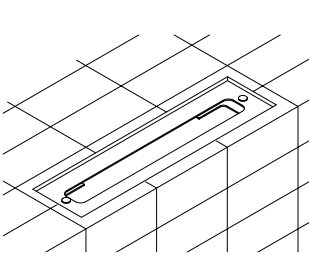

2.

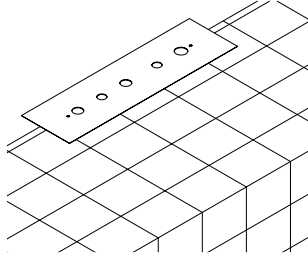

3.

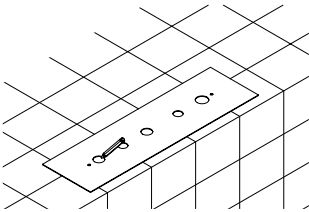

4.

- Segnare le forature
- Mark the drill holes
- Marquer les trous
- Die Bohrlöcher markieren
- Marcar los agujeros

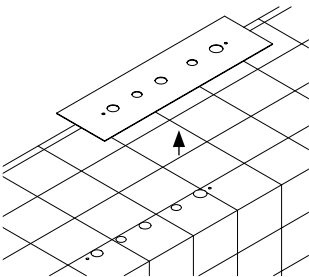

5.

- Rimuovere la dima e forare seguendo i diametri indicati nella figura 5
- Remove the template and drill according to the diameters given in Ill. 5
- Enlever le gabarit et forer selon les diamètres indiqués sur la figure 5
- Die Schablone entfernen und Löcher konform mit den Durchschnitten in Abb. 5 bohren
- Quitar la galga y perforar según los diámetros de la figura 5

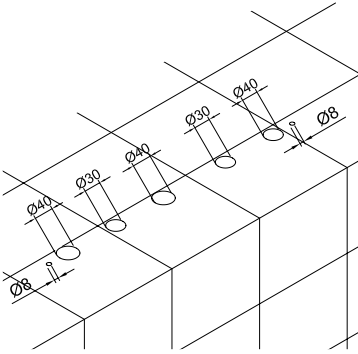

6. ART. C965

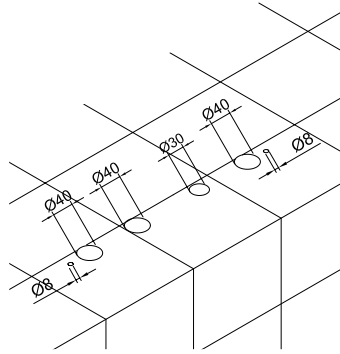

6. ART. C967



- Proseguire l'installazione seguendo dal punto 1 di pagina 7.
- Continue with the installation as shown after Number 1 on page 7.
- Continuer l'installation à partir du point 1 de la page 7.
- Mit der Installation wie nach Nr. 1 auf Seite 7 gezeigt weiterfahren.
- Continuar la instalación desde el punto 1 en la página 7.

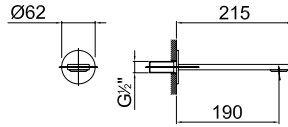
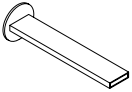

ART. C945

Bocca a muro / Wall-mount spout / Bec mural / Wandeinlauf /
Caño a pared

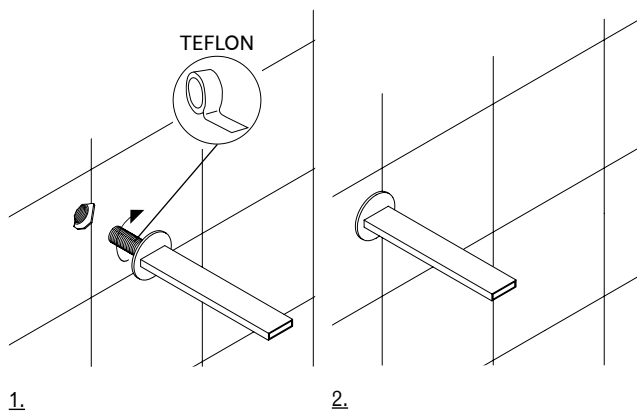

Sostituzione vitone / Bolt Replacement / Remplacement de la tête
 Oberteilersetzung / Sustitucion rosca de extrusion

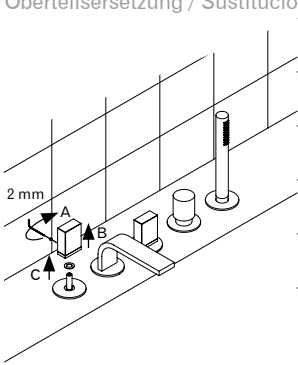

1.

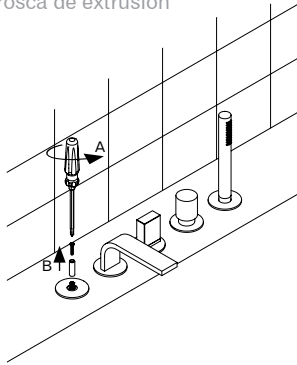

2.

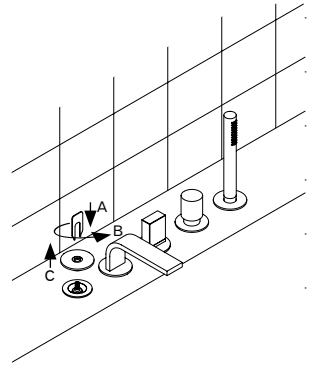

3.

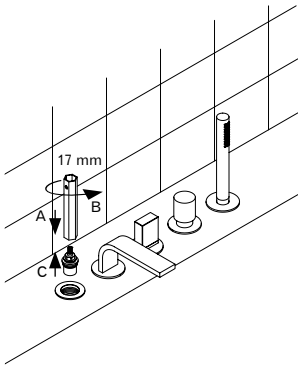

4.

Rimontare seguendo il procedimento inverso (4-3-2-1).

Replace following the instructions in reverse order (4-3-2-1).

Re-installer au contraire du procédé (4-3-2-1).

Die umgekehrte Vorgehensweise folgen um die Teil wieder zu installieren (4-3-2-1).

Colocar según el procedimiento inverso (4-3-2-1).

Sostituzione aeratore / Substitute aerator / Remplacement de l'aérateur / Den
Lüfter auswesceln / Sustituir el aireador

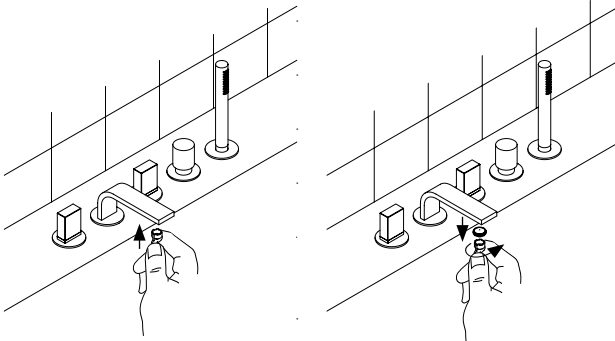

1.

Rimontare seguendo il procedimento inverso (2-1)

Replace following the instructions in reverse order (2-1)

Re-installer au contraire du procédé (2-1)

Die umgekehrte Vorgehensweise folgen um die Teil wie der zu installieren (2-1)

Colocar según el procedimiento inverso (2-1)

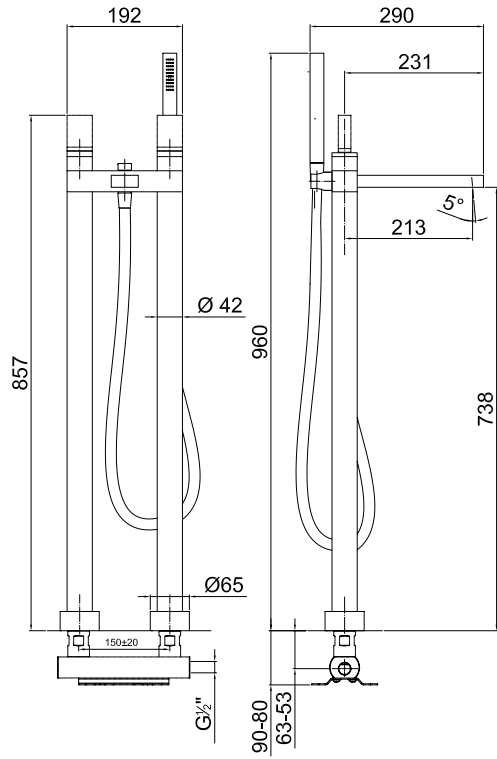
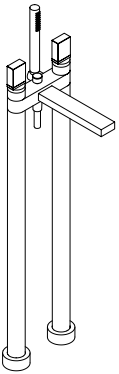

ART. C980SB Parte esterna / External pieces / Parties externes / Up-Teil / Parte externa

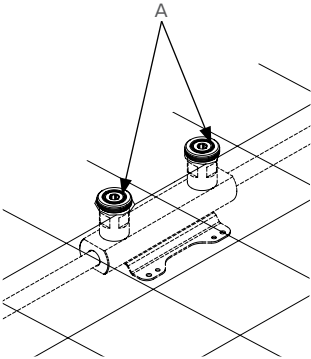

- Verificare la presenza degli o' ring (A)
- Check for the presence of o'ring (A)
- Vérifier la présence du joint torique (A)
- Prüfen auf das Vorhandensein von O-Ring-(A)
- Verificar la presencia de la junta tórica (A)

1.

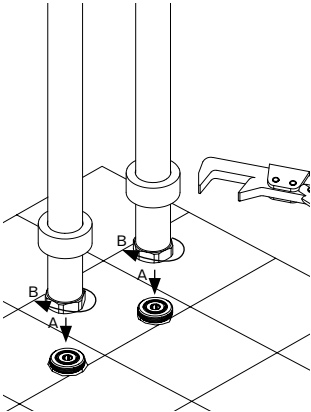

2.

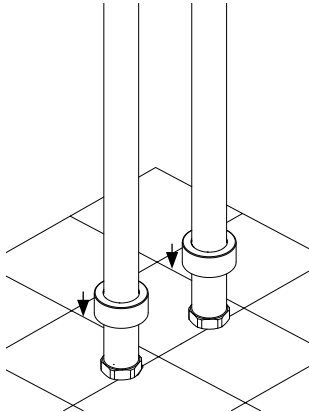

3.

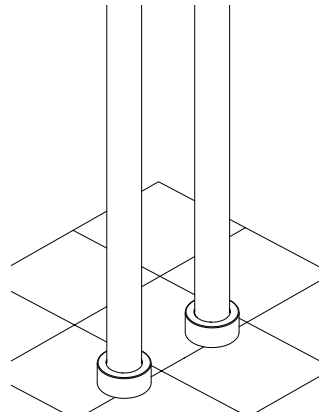

4.

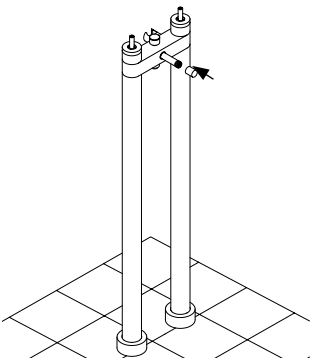

5.

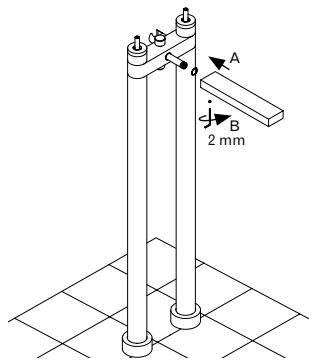

6.

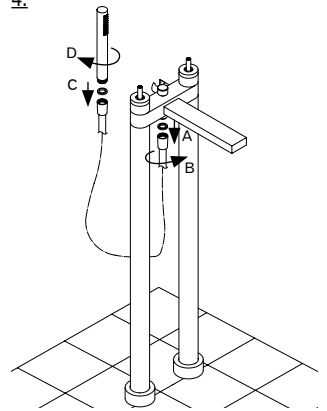

7.

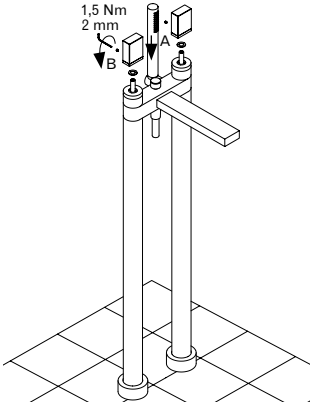

8.

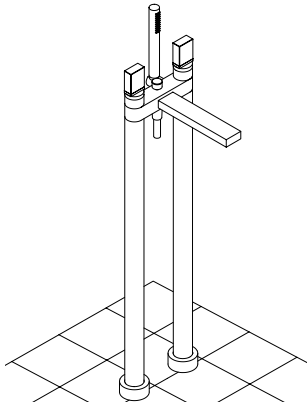

9.

Regolazioni / Adjustments / Ajustements / Anpassungen / Ajustes

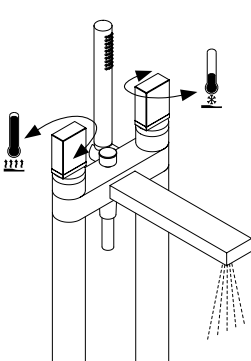

1.

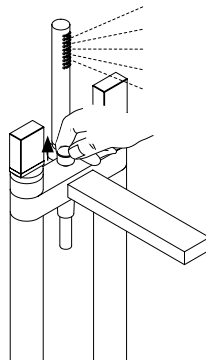

2.

Sostituzione vitone / Bolt replacement / Remplacement de la tête
Oberteilersetzung / Sustitucion rosca de extrusion
 Per art. C980SB

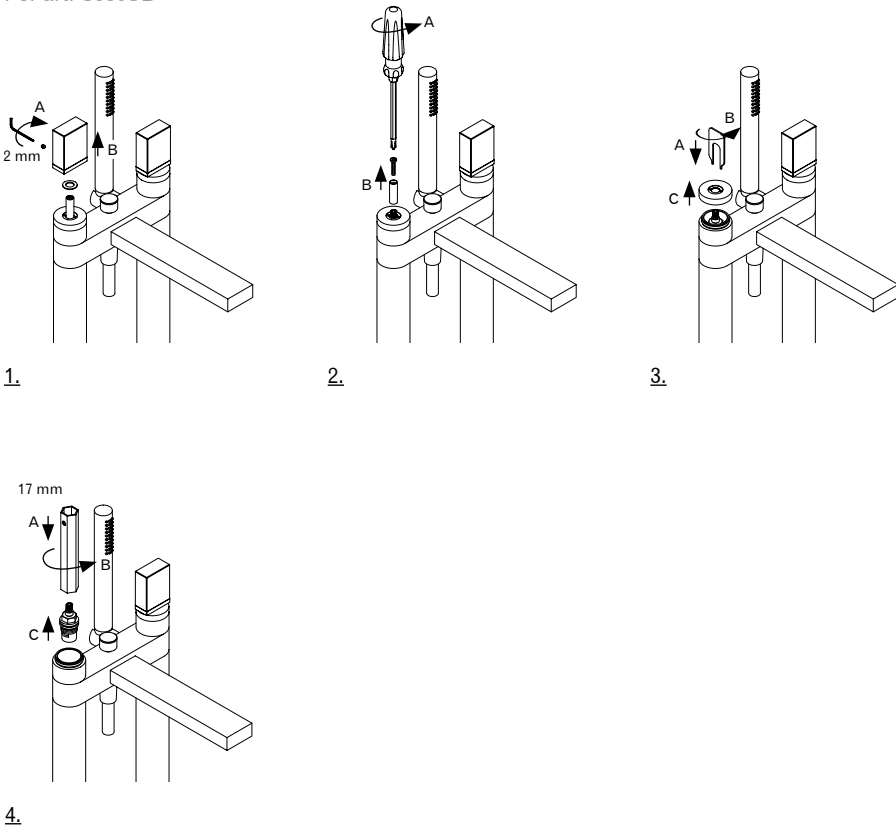

Rimontare seguendo il procedimento inverso (4-3-2-1)
 Replace following the instructions in reverse order (4-3-2-1)
 Re-installer au contraire du procédé (4-3-2-1)
 Die umgekehrte Vorgehensweise folgen um die Teil wie der zu installieren
 (4-3-2-1)
 Colocar según el procedimiento inverso (4-3-2-1)

Sostituzione deviatore / Bolt replacement/ Remplacement de la tête
Oberteilersetzung / Sustitucion rosca de extrusion
Per art. C980SB

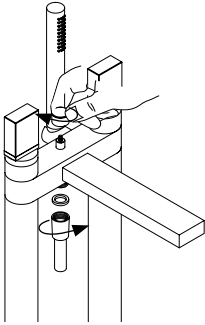

1.

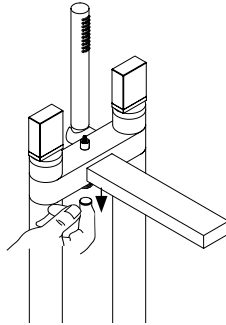

2.

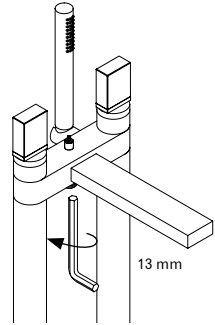

3.

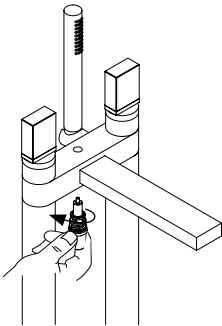

4.

Rimontare seguendo il procedimento inverso (3-2-1)

Replace following the instructions in reverse order (3-2-1)

Re-installer au contraire du procédé (3-2-1)

Die umgekehrte Vorgehensweise folgen um die Teil wie der zu installieren (3-2-1)

Colocar según el procedimiento inverso (3-2-1)

Sostituzione rompigetto / Substitute aerator / Remplacement de l'aérateur
 Den Lüfter auswechseln / Sustituir el aireador
 Per art. B280B

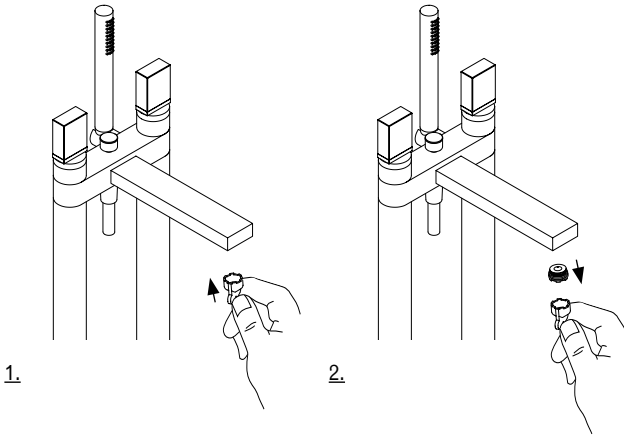

Rimontare seguendo il procedimento inverso (2-1)
 Replace following the instructions in reverse order (2-1)
 Re-installer au contraire du procédé (2-1)
 Die umgekehrte Vorgehensweise folgen um die Teil wie der zu installieren (2-1)
 Colocar según el procedimiento inverso (2-1)

Dati tecnici

Pressione minima	1 BAR
Pressione massima	10 BAR
Pressione di esercizio consigliata	2-5 BAR
Temperatura massima	80°
Temperatura massima consigliata	65°
Differenza massima di pressione in arrivo (calda - fredda)	1.5 BAR

Applicazioni

Questi miscelatori possono essere utilizzati con accumulatori di acqua calda a pressione o con scaldabagni istantanei.

Avvertenze

Prima di installare é necessario spurgare in modo accurato le tubazioni di alimentazione.

Ricordarsi che l'acqua calda deve essere

SEMPRE collegata al tubetto o flessibile di **SINISTRA**.

Technische Daten

Minimum druck	1 BAR
Höchste druck	10 BAR
Empfehlener druck	2-5 BAR
Höchste wasser Temperatur	80°
Empfehlener höchste Wassertemperatur	65°
Höchste einkommende Drucksunterschied (Warm - kalt)	1.5 BAR

Betriebsanweisungen

Diese Mischer sind sowie für Heisswasserspeicher als auch für Durchlaufhitzer geeignet.

Note

Die Verbindungsröhre vor der Montage sorgfältig putzen.

Das warme Wasser muss **IMMER** mit dem linken

RÖHRCHEN ODER Flexschlauch verbunden werden

ITALY.

Technical data

Minimum pressure	1 BAR
Maximum pressure	10 BAR
Recommended working pressure	2-5 BAR
Maximum water temperature	80°
Maximum water temperature recommended	65°
Maximum in-let pressure difference (hot - cold)	1.5 BAR

Operating instructions

These mixers can be used with cumulus boilers or instantaneous water heaters.

Warning

The supplying pipes must be carefully cleaned before installation.

Remember that the hot water supply must **ALWAYS** be connected to the tube on the **LEFT**.

GERMANY.

Datos Técnicos

Pression mínima	1 BAR
Pression máxima	10 BAR
Pression de trabajo aconsejada	2-5 BAR
Temperatura máxima	80°
Temperatura máxima aconsejada	65°
Diferencial máxima de presión de entrada (caliente - fria)	1.5 BAR

Aplicaciones

Estos monomandos pueden ser utilizados con acumuladores de agua caliente a presión.

Advertencias

Antes de conectar el monomando es necesario purgar correctamente la instalación hidráulica de alimentación de cualquier impureza que pueda tener.

Recuerde que el agua caliente debe ser **SIEMPRE** conectada al tubo o flexo de la **IZQUIERDA**.

ENGLAND.

Caractéristiques techniques

Pression minimum	1 BAR
Pression maximum	10 BAR
Pression optimale de service	2-5 BAR
Température maximum	80°
Température maximum optimale	65°
Différence maximum de Pression d'arrivée (chaud - froid)	1.5 BAR

Mode d'emploi

Ces mitigeurs peuvent être utilisés avec accumulateurs d'eau chaude à pression ou avec des chauffe-eau instantanés.

Note

Il est indispensable que les raccords d'alimentation soient purgés avant la mise en place de l'appareil.

Se rappeler que l'eau chaude doit être **TOUJOURS** liée au petit tuyau ou au flexible de **GAUCHE**.

SPAIN.

FRANCE.

Cura del prodotto

La pulizia delle superfici va fatta utilizzando un sapone liquido diluito in acqua.

Non usare mai in nessun caso detersivi liquidi contenenti sostanze abrasive o a base di acido muriatico, spugne abrasive, aceto, ammoniaca, acetone, candeggina, acidi di uso domestico, disinfettanti vari.

ATTENZIONE! L'impiego di prodotti non consigliati può deteriorare irrimediabilmente le superfici, nel qual caso il produttore non risponderà del danno.

L'azienda si riserva in qualunque momento di apportare senza preavviso modifiche a prodotti e accessori.

I dati riprodotti in questo documento hanno carattere informativo e non sono vincolanti.

ITALY.**Advice on product care**

To clean the surface use a soap and water solution.

Never use for any reason cleaning solutions containing abrasive substances, chloric acids, ammonia, vinegar, bleach, domestic acids, disinfectants, or anytype of abrasive pad.

WARNING! Incorrect cleaning may permanently ruin the surface of the products and in such case the manufacturer may not be held liable for damage.

The Manufacturer reserves the right to modify product and accessories at any time without prior notice. Data, products and sketches included in this document are just for information and do not bind the producer.

ENGLAND.**Conseils pour l'entretien du produit**

La poussière en surface devra être faite en utilisant un savon liquide dilué dans l'eau.

Ne jamais utiliser en aucun cas des détergents liquides contenant des substances abrasives ou à base d'acide, nid'éponges abrasives, vinaigre, ammoniacque, acétone, eau de Javel, acides à usage domestique, désinfectants divers.

ATTENTION! L'emploi de produits non conseillés peut détériorer irrémédiablement la surface des articles pour lesquels le fabricant ne sera pas responsable.

La société se réserve le droit de modifier ses produits et ses accessoires à tout moment et sans préavis. Informations, produits et croquis reproduits dans ce documents sont de nature informative et ne sont pas contractuels.

FRANCE.**Pflege hinweise unserer artikel**

Zur Reinigung empfehlen wir Wasser und flüssige Seife.

Verwenden Sie bitte nie flüssige Reinigungsmittel, die Schmirgel, Salzsäure, Essig, Ammoniak, Aceton, Bleichlange, Desinfektionsmittel u.s.w. enthalten.

WARNUNG! Der Gebrauch solcher Mittel kann unsere Artikel beschädigen und in diesem Fall gewährt Hersteller keine Garantie.

Der Hersteller behalt sich das Recht vor jederzeit Änderungen an seinen Produkten und Zubehörteilen ohne Vorbescheid vorzunehmen. Katalogangaben sowie Abbindungen, Maß- und Leistungsangaben sind unverbindlich.

GERMANY.**Consejos para el cuidado del producto**

La limpieza de las superficies se hace utilizando un jabón líquido diluido en agua.

No usar en ningún caso detergentes líquidos que contengan sustancias abrasivas ó a base de ácido clorhídrico, estropajoabrasivos, amoniaco, acetona, lejía, ácidos de uso doméstico, desinfectantes varios.

ATENCIÓN! El uso de productos desaconsejados puede danar irremediamente las superficies de los elementos, de lo cual el fabricante no se hará responsable en ningún caso.

La sociedad se reserva el derecho de modificar sus productos y accesorios en cualquier momento y sin previo aviso.

SPAIN.



Disegni e grafica: www.dipi-designs.com 1129000100000000 Rev. 0

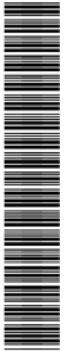

**Australian Standard
Installation**

Products shall be installed in accordance with AS/NZS 3500 series of standards.
Installer shall ensure that the flow controlled aerator is tightened to prevent removal by hand.