

VOLUME (l)  
VOLUMEN (l)

MAX. LOAD (kg)  
MAX. BELASTUNG (kg)

FLOOR LOAD (kg/m<sup>2</sup>)  
BODENBELASTUNG (kg/m<sup>2</sup>)

650

910

320

- - Spot for el. cable 3×2.5mm<sup>2</sup> (230V, 16A/L, N, ≐) L=2.5m
- - Platz Stromkabel 3 × 2,5 mm<sup>2</sup> (230 V, 16 A/L, N, ≐); L = 2,5 m
- - Spot for additional el. cable 6mm<sup>2</sup>, for earthing of steel parts, L=2.5m
- - Platz zusätzlicher Stromkabel 6 mm<sup>2</sup> für Erdung von Metallteilen; L = 2,5 m

- ⊗ - Connection of hot and cold water 1/2" min 0.2Mpa, max 0.4Mpa
- ⊗ - Anschluss Warm- und Kaltwasser 1/2" min 0,2 Mpa, max 0,4 Mpa

- - Drain spot Ø 50mm
- - Abflussplatz Ø 50 mm
- ▣ - Panel - option
- ▣ - Möglichkeit - Schürze

INSTALLATION RECOMMENDATION  
MONTAGEEMPFEHLUNG

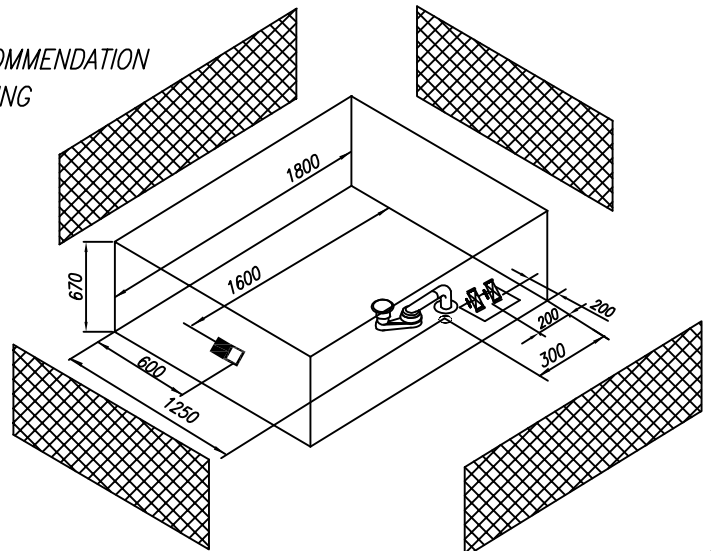

Recommended overflow set Vorgeschlagene Überlaufgarnitur	PAL 650
Recommendations for the installation of bathtub without panel Empfehlungen für die Montage von Badewannen ohne Schürze	Nr. MK 03
Recommendations for the installation of bathtub with panel Empfehlungen für die Montage von Badewannen mit Schürze	Nr. MK 01
Option of the built-in bathtub base Möglichkeit des Sockels für die Badewannen ohne Schürze	Nr. MK 10 -2x PKK 800 -2x
Option of the bathtub base with panel Möglichkeit des Sockels für die Badewannen mit Schürze	pre-assembled vormontiert

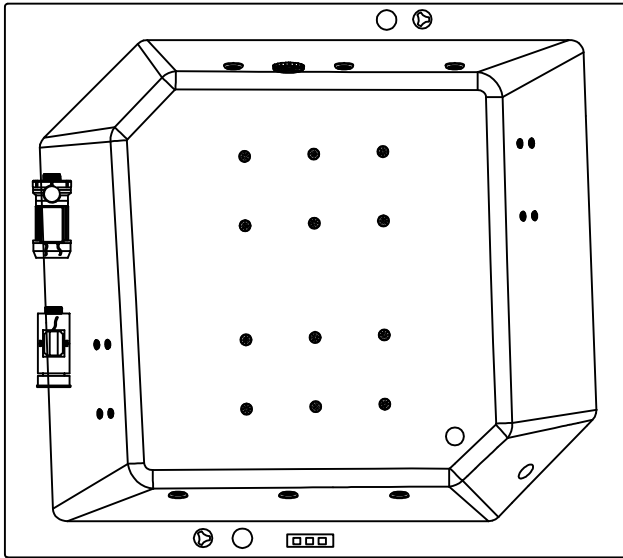

WATER AND AIR MASSAGE SYSTEM

- PUMP P=1250W
- BLOWER P=800W
- ELECTRONIC SWITCH
- 6 WATER SUPER JETS
- 12 AIR JETS
- 2x4 WATER MICROJETS
- 2x AIR CONTROLLER

WASSER UND LUFT MASSAGESYSTEM

- WASSERPUMPE P = 1250 W
- LUFTPUMPE P = 800 W
- ELEKTROSCHALTER
- 6 SUPER-WASSERDÜSEN
- 12 LUFTDÜSEN
- 2 x 4 MIKRO-WASSERDÜSEN
- 2x AIR CONTROLLER

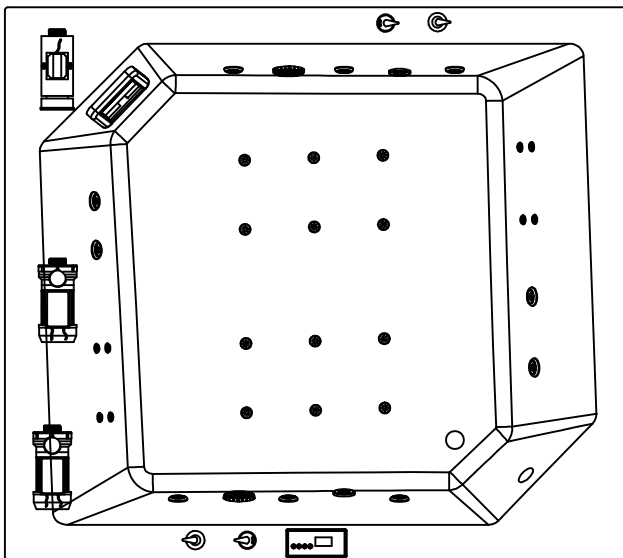

LUXUS+ MASSAGE SYSTEM

- PUMP P=1250W
- PUMP P=650W
- BLOWER P=800W
- HEATER P=2000W
- ELECTRONIC SWITCH
- 2x AIR CONTROLLER
- 10 WATER SUPER JETS
- 12 AIR JETS
- 2x4 WATER MICROJETS
- WATER FILTRATION
- CHROMOTHERAPY
- OZONE FOR DISINFECTION

LUXUS+ MASSAGESYSTEM

- WASSERPUMPE P = 1250 W
- WASSERPUMPE P = 650 W
- LUFTPUMPE P = 800 W
- HEIZKÖRPER P = 2000 W
- ELEKTROSCHALTER
- 2x AIR CONTROLLER
- 10 SUPER-WASSERDÜSEN
- 12 LUFTDÜSEN
- 2 x 4 MIKRO-WASSERDÜSEN
- WASSERFILTRIERUNG
- CHROMOTHERAPIE
- OZON FÜR DESINFEKTION

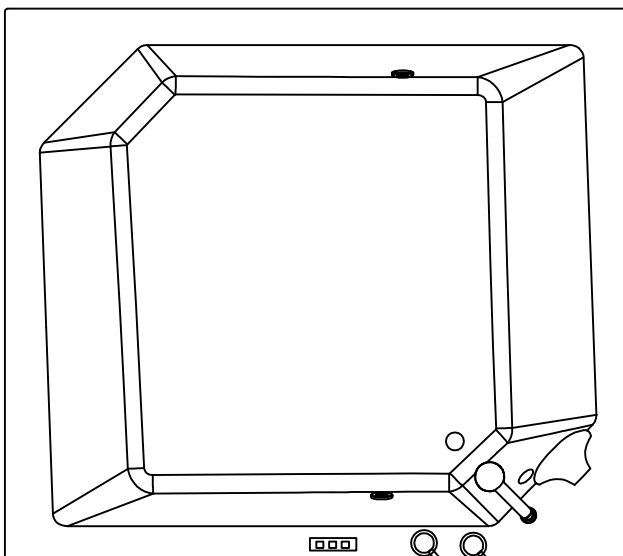

- OPTION FIXTURE AND SHOWER HANDLE
- OPTION CHROMOTHERAPY

- MÖGLICHKEIT WASSERHAHN UND DUSCHE
- MÖGLICHKEIT CHROMOTHERAPIE